

2020: Data is provided as a text file available on the 275 webpage. Five filters were used and it will be necessary to pull each filter's values out into separate files using a text editor. "Pluma" or "Leappad" or both available on the linux vm/machines to do this editing.

### 3. Photoelectric Effect

#### 3.1. Purpose

- To demonstrate the relationship between the kinetic energy of ejected electrons and the frequency of the photons responsible for their emission from a metal.
- To determine a value for Planck's constant.
- To determine a value for the work function of the metal of the cathode in a phototube.

#### 3.2. Theory

A phototube consists of two electrodes enclosed in an evacuated glass tube. One electrode has a large photosensitive surface and is called the cathode or emitter. The other electrode is in the form of a wire and is called the anode or collector. The electrons of the emitter material are to be collected by the collector wire.

In normal operation the anode is held at a small positive potential with respect to the cathode. When the cathode is exposed to light, electrons are ejected from its photosensitive surface. These electrons are attracted to the positive anode and form a current that will be measured using a galvanometer or picoammeter.

The *kinetic energy* of the ejected electrons is determined by the *frequency* of light striking the phototube. The *quantity* of ejected electrons is dependent on the *intensity* of the light. Classical physics fails to predict this behavior. The maximum kinetic energy of the photoelectrons is given by equation 3.1:

$$KE_{max} = h\nu - W \quad (3.1)$$

where  $h$  = Planck's constant,  $\nu$  = frequency of the photon,  $W$  = the work function

One goal of this experiment is to measure the maximum kinetic energy of the ejected electrons. Equation 3.1 shows the maximum kinetic energy depends directly on the frequency of the incoming photons.

The ejected electrons have some affinity to the metal. The work function is the energy required to knock an electron out from the surface of the metal and then have zero kinetic energy left over. The work function is constant for a given metal.

If the potential applied to the anode is gradually decreased and then made negative, the electrons ejected from the cathode will not have enough kinetic energy to reach the anode and add to the current through picoammeter. At a certain voltage called the "stopping potential" the electron current from the cathode to the anode will become zero. At that point all electrons are stopped and repelled back to the cathode. The maximum kinetic energy of those last repelled electrons is related to the stopping voltage by equation 3.2.

$$KE_{max} = eV_{stop} \quad (3.2)$$

where  $e$  = the electron's charge (1.602e 19 coulombs) and  $V$  = the stopping potential.

By experimentally determining the stopping potential for a few different photon energies (values of  $\nu$ ), a graph of  $eV$  versus  $\nu$  will give a value for  $h$  (from the slope) and  $W$  (from the intercept).

In regards to photons, a useful formula is the relationship between wavelength  $\lambda$  and the frequency  $\nu$  of light shown in equation 3.3.

$$c = \lambda\nu \quad (3.3)$$

### 3.3. Procedure

A mercury arc lamp is used as a source of photons. These photons are directed to the photosensitive plate of an RCA934 phototube. The emission plate of this tube is a cesium antimony alloy. The RCA934 tube is generally used to measure light intensity; its output current is related to the amount of light falling on it.

A mercury arc lamp is used with three cutoff filters on a rotating wheel. This provides an effective way of obtaining several distinct frequencies of light. These filters can be considered low pass filters in terms of frequency and high pass filters in terms of wavelength. This is shown in Figure 3.1.

*These filter characteristics are for the wheel. The 2020 data used filters which selected a specific mercury emission line. The 275 webpage has the curves for these filters.*

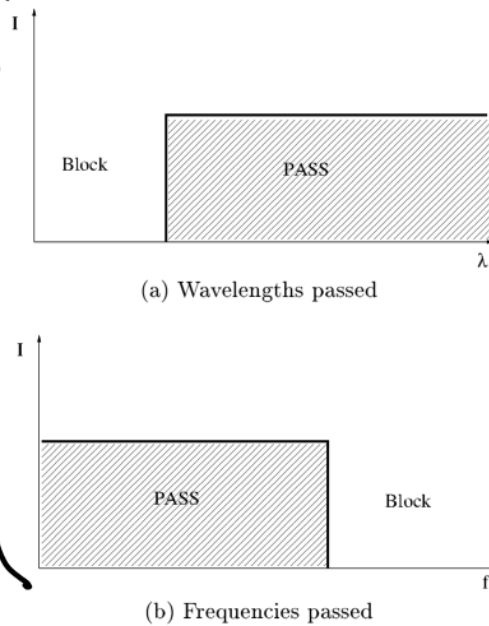

Figure 3.1.: Ideal filter behavior in terms of wavelength and frequency.

Caution: The arc lamp housing will get extremely hot and can produce a burn to skin. Move the lamp housing by the bottom or base, do not touch the top. Also the filters can be melted if the lamp is positioned less than one or two centimeters away.

Changing the lamp separation during a trial will make a problem with the data. The lamp position should be adjusted only between filter trials, not part way through a particular filter trial. If it is accidentally moved, back up to your last voltage and adjust the lamp position until you get the same current reading.

Figure 3.2 shows the apparatus in schematic form. Two rheostats allow easy control of the potential used to repel the electrons. This voltage is read on a DVM (V in the diagram). The electron current is detected by a picoammeter G.

1. The apparatus is generally ready to use; picoammeter, DC power supply and DVM (digital volt meter) will be connected to the apparatus for testing.
2. Set the DC supply to 3.0V for the duration of the experiment.
3. The three wavelength cutoff filters are mounted on a rotating wheel. There is also an empty window (no filter) on the wheel. Select the 435nm filter. Calculate and record the wavelength values that these frequencies correspond to.
4. Position the lamp about 15 to 20 cm from the apparatus and filter wheel to start. This will be adjusted as needed.

### 3. Photoelectric Effect

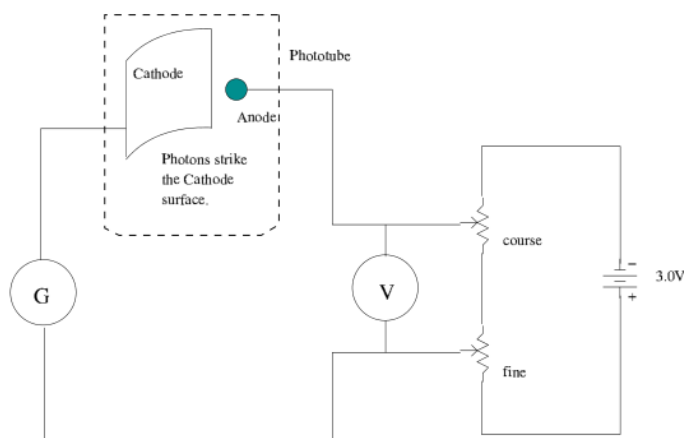

Figure 3.2.: Planck's constant apparatus

5. Turn on the Hg arc lamp and wait for three to four minutes for it to warm up to full brightness.
6. Set the DVM to measure volts DC. The picoammeter scale should be adjusted to less sensitive scale initially.
7. Adjust each rheostat on the Planck's constant apparatus to a minimum in terms of DC voltage (full ccw).
8. Adjust the picoammeter range and the lamp filter separation for a suitable current. We generally use the 2 or the 20  $\mu A$  scale. You will have a maximum current for a minimum repelling voltage<sup>1</sup>.
9. Now increase the repelling potential by steps of 0.10 volts and record the current and voltage readings. When the current values change very little, take three or four more data points in this area; that should suffice for the graphs. It will not be necessary to go above 1.5V regardless of which filter you are using.
10. Repeat for each of the next two filters on the wheel, and any additional filters or light sources provided.

### 3.4. Analysis

- Plot graphs of current versus repelling potential for each filter. You might be able to fit the data with a spline, a straight line fit is not appropriate.
- On these graphs select the voltage at which the current stopped changing.<sup>2</sup> The stopping potential is estimated as that value of voltage at which the current becomes approximately constant. Assistance from the lab instructor is helpful. This step is subjective.
- Use the above ~~three~~ <sup>five</sup> stopping voltages to plot a graph of  $KE_{max} = eV$  versus  $\nu$ .  $e$  is the electron charge in coulombs and  $V$  is the stopping potential in volts. Use  $\nu = \frac{c}{\lambda}$  with  $\lambda$  being the value of the filter used.
- Determine a value for Planck's constant  $h$  and work function  $W$  with error.

<sup>1</sup>The voltage minimum is slightly above 0.00V, this is not an issue.

<sup>2</sup>Manufacturer's note: In fact the emission from the anode makes this difficult. Anode emission probably occurs due to a small amount of photosensitive material getting deposited on it during construction of the photocell. Although the relative number of electrons emitted by the anode is very small, their contribution to the current is appreciable. Thus the potential required to completely stop the electrons emitted by the cathode is greater than the potential at which the net current is zero.

### 3.5. Questions

1. Explain why using a mercury arc lamp is preferable over an incandescent lamp for this experiment. Consider the spectrum of each light source and characteristic curve (% transmission versus frequency) of the filters.
2. An electron is ejected from a sheet of iron and has a velocity of  $4.94 \frac{m}{s}$ . What was the wavelength of the photon responsible for the electron's emission?
3. What is the value of the work function for Cesium and for Antimony in electron volts?
4. What very simple and useful vacuum tube device make use of the photoelectric effect? That is, the device has a specific function in electronics.
5. Referring to Figure 3.1, what would the equivalent graph (ideal) of Intensity versus photon energy look like?

No fr  
2020